



Mactenn

SYSTEMS LIMITED

Macawber Europe

INFORMATION SHEET

1-1-4

MAXSANDFLO

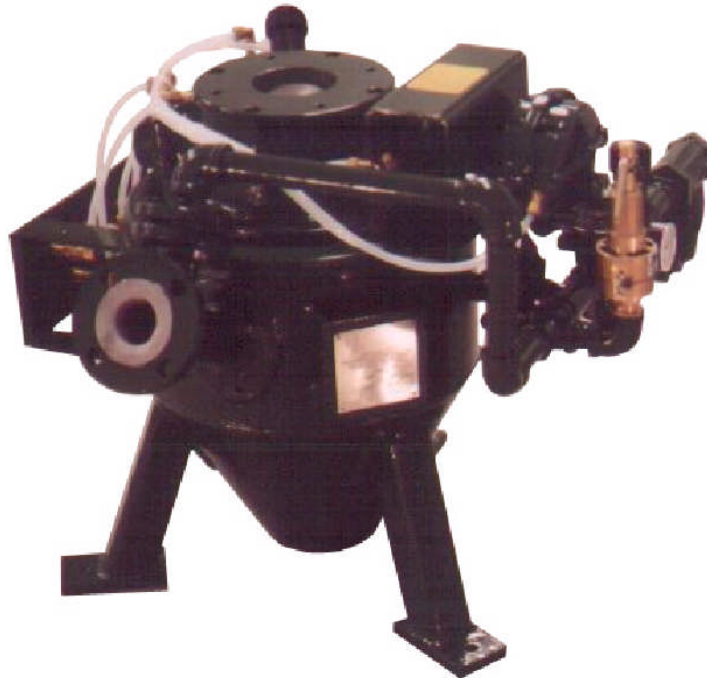

The **MaxSandflo** is a development of the **Maxflo** low velocity dense-phase conveying system. It is a value engineered system specifically for the special needs of sand only handling systems.

Designed for little or no maintenance in locations where maintenance attention is at a premium. No constantly moving parts and simple controls. Fitted with the famous **Inflatek Valve** which is well proven to perform reliably when operating with abrasive materials. The only valve that can close and seal on a static column of material and support a pressure differential.

Transfer of velocity of the sand is controlled to very low values to allow the use of standard pipe work without maintenance from pipe wear. This also benefits air usage which is extremely low and very economical.

No pipeline boosters are required which are unnecessary for a controlled low sand velocity through the pipeline. This saves further maintenance and the cost of running air lines to the booster connections. As of 2005 more than 4000 systems are in operation throughout the world since 1977 when it was introduced.

The system design and components are subject to continuous development and improvement for lower product cost and performance.

Mactenn

A Macawber Group Company

ADVANCED PNEUMATIC CONVEYING & INJECTION SYSTEMS
VALVES FOR ABRASIVE MATERIALS AND PRESSURE DUTY
BATCH MIXING AND INGREDIENT CONTROL
COMPLETE BULK MATERIAL SYSTEM DESIGN AND TURNKEY SUPPLY

Mactenn

Mactenn

SYSTEMS LIMITED
Macawber Europe

INFORMATION SHEET

1-1-4

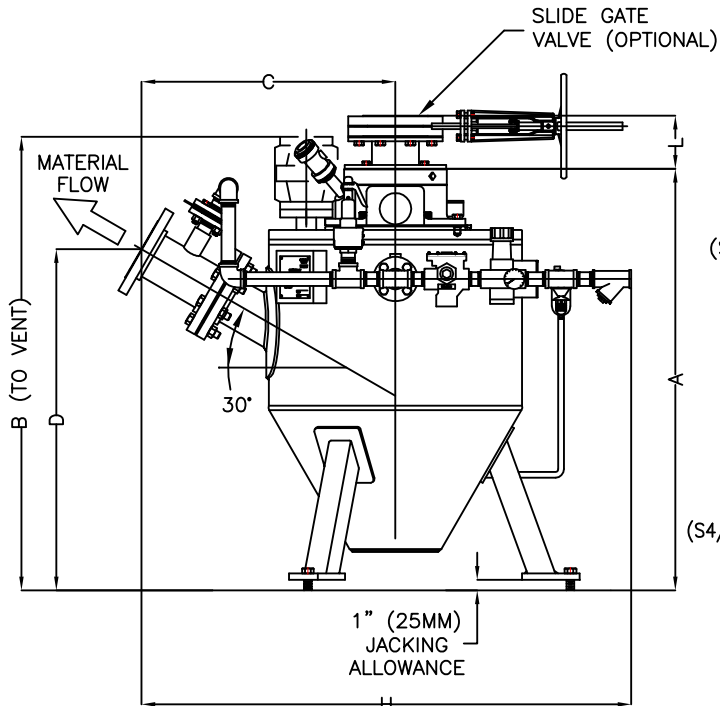
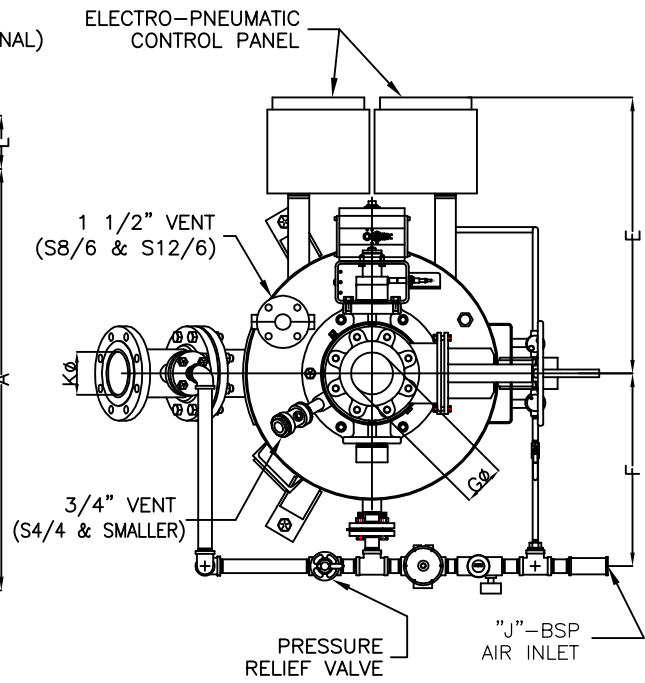
MAXSANDFLO**SIDE VIEW****PLAN VIEW**

MODEL	DIMENSIONS (MM)											NET WT. KG
	A	B	C	D	E	F	G	H	J	K	L	
S.57/4-2	689	743	429	559	533	356	100	930	25	51	127	165
S.85/4-3	873	933	511	664	616	458	100	1048	25	76	127	230
S.114/4-4	1022	1067	616	823	670	467	100	1238	25	102	127	245
S.228/6-5	1181	1280	721	937	746	635	150	1407	50	127	133	470
S.342/6-6	1480	1518	724	981	759	571	150	1438	50	152	133	500
S.570/8-8	1499	1575	885	1067	889	864	200	1699	50	203	146	907
S.857/8-10	1499	1575	885	1067	889	864	200	1699	80	203	146	1134

INFORMATION NOT CERTIFIED FOR INSTALLATION PURPOSES

Mactenn**A Macawber Group Company**

ADVANCED PNEUMATIC CONVEYING & INJECTION SYSTEMS
VALVES FOR ABRASIVE MATERIALS AND PRESSURE DUTY
BATCH MIXING AND INGREDIENT CONTROL
COMPLETE BULK MATERIAL SYSTEM DESIGN AND TURNKEY SUPPLY